



## Technical data

E

- **Interchange:** Stucchi DP4
- Occlusion: flat face
- Locking: lever with safety devices
- Material: steel and aluminum
- Finishing: Zn-Fe (Cr III), Zn-Ni, cataphoresis.
- Threads: BSP - NPT - SAE - METRIC
- Standard seals: NBR and PU
- Working temperature: -25 °C +100 °C
- Optional seals: FKM, EPDM or more.
- Working pressure: 350 bar
- Connection under residual pressure: allowed (male side only)

## Technische Merkmale

D

- **Norm:** Stucchi DP4
- Verschluss: flachdichtend
- Kupplung: Hebel mit doppelter Sicherung
- Werkstoff: Stahl und Aluminum
- Ausführung: Zn-Fe (Cr III), Zn-Ni, Kataphorese.
- Gewinde: BSP – NPT – SAE – METRISCHE
- Standard-Dichtungen: NBR und PU
- Betriebstemperatur: -25 °C +100 °C
- Dichtungen nach Wahl: FKM, EPDM, usw.
- Betriebsdruck: 350 bar
- Kuppeln unter Restdruck: erlaubt (nur männliche Seite)

Nominal size				Max working pressure MPa	Rated flow l/min	Max flow rate l/min	Min burst pressure			Fluid spillage cc
DNP	BG	ISO	Ømm				Male MPa	Female MPa	Coupled MPa	
13	2	10	8.6	35	23	46	140	140	140	0.01

1 MPa = 145.04 psi • 1 l = 0.264 gal

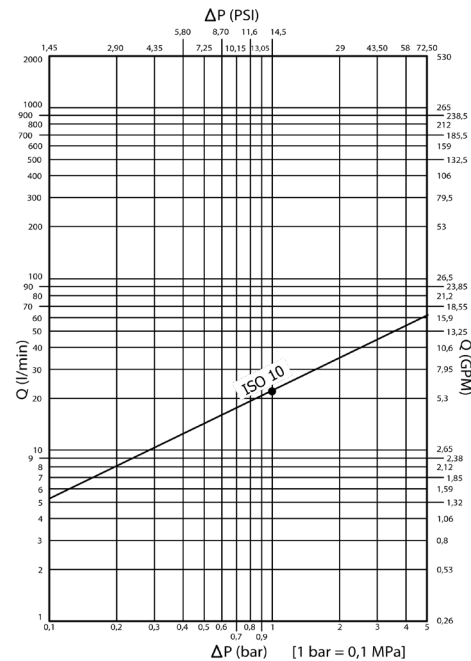

PSQ2 DIMENSION

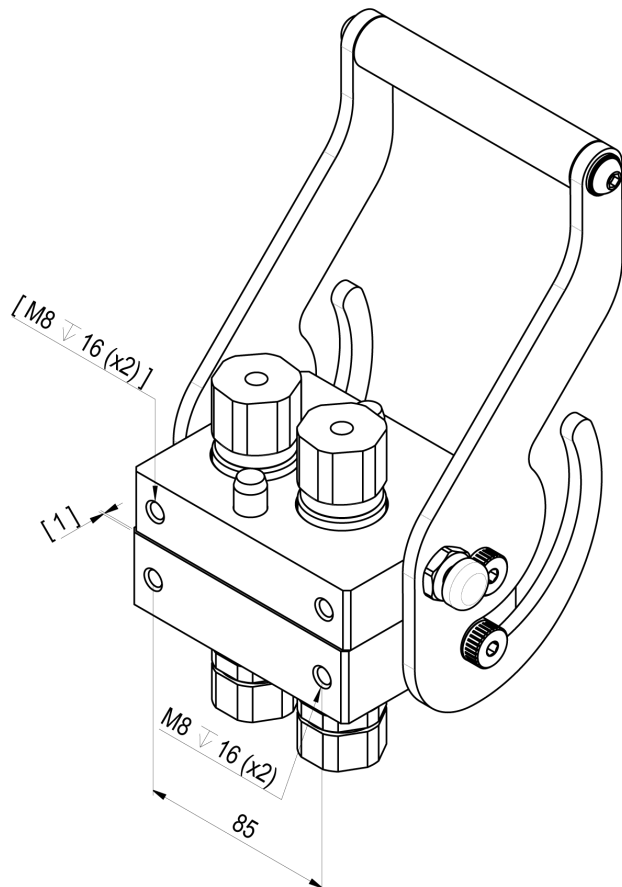
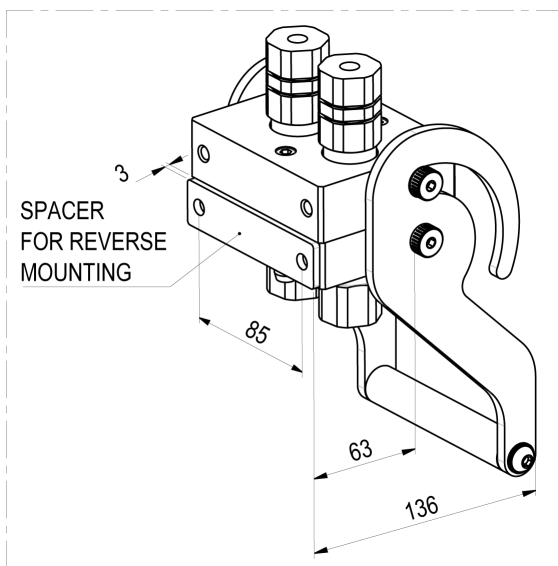
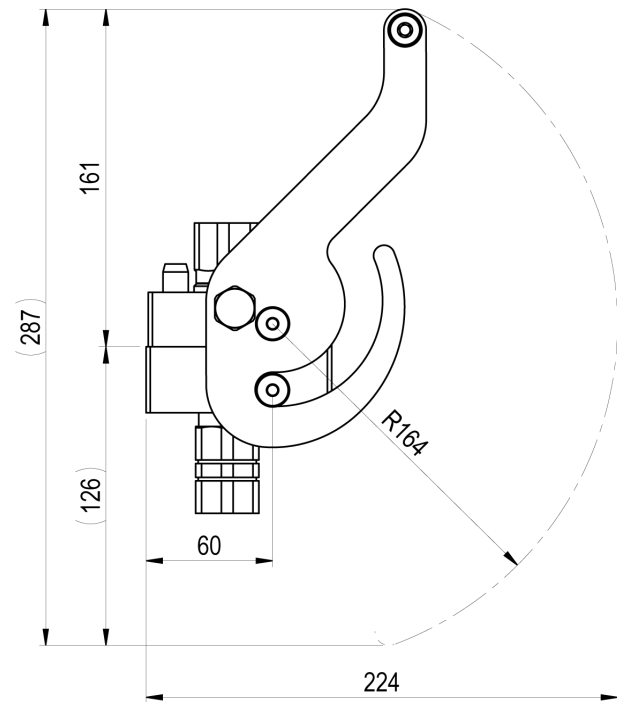
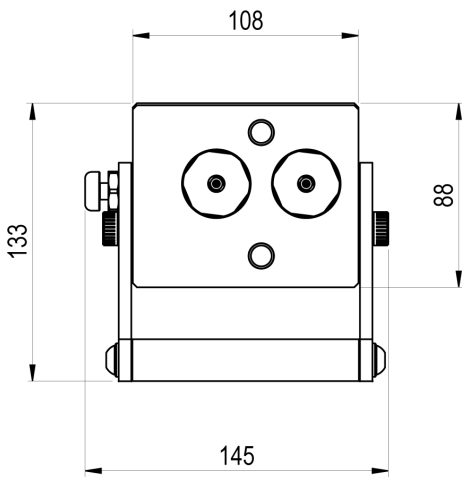
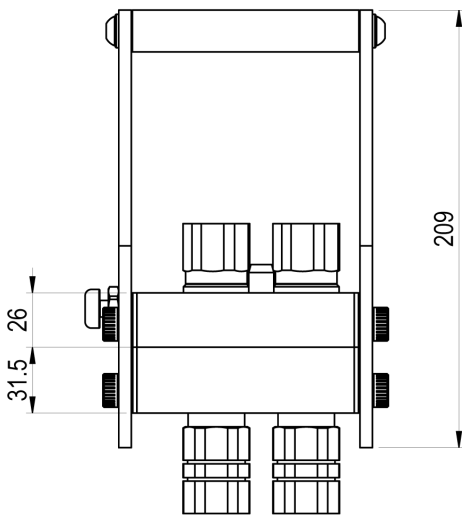

## PSQ2 FIXED



THREADS	DNP	BG	ISO	Housing	No. Couplings	Thread	STANDARD	FIXED PART CODE	
								CODE	Weight (g)
<b>IG 1</b>	13	2	10	2	2	BSP 1/4"	DIN 3852-2-X	PSQ2.1306.002	
	13	2	10	2	2	NPTF 1/4"	ANSI B1.20.3	PSQ2.1306.012	
	13	2	10	2	2	BSP 3/8"	DIN 3852-2-X	PSQ2.1310.112	
	13	2	10	2	2	NPTF 3/8"	ANSI B1.20.3	PSQ2.1310.012	
	13	2	10	2	2	BSP 1/2"	DIN 3852-2-X	PSQ2.1313.112	
	13	2	10	2	2	NPTF 1/2"	ANSI B1.20.3	PSQ2.1313.012	
	13	2	10	2	2	M16x1.5	ISO 6149-1	PSQ2.1316.102	
<b>IG 2</b>	13	2	10	2	2	9/16" - 18 UNF 2B	SAE J 1926-1	PSQ2.1315.032	
	13	2	10	2	2	3/4" - 16 UNF 2B	SAE J 1926-1	PSQ2.1319.032	
	13	2	10	2	2	M22x1.5	SAE J 2244/1	PSQ2.1322.102	
<b>AG 5</b>	13	2	10	2	2	BSP 1/2"	BS B5200	PSQ2.1313.702	

## PSQ2 MOBILE



THREADS	DNP	BG	ISO	Housing	Number of Couplings	Thread	STANDARD	MOBILE PART CODE	
								CODE	Weight (g)
<b>IG 1</b>	13	2	10	2	2	BSP 1/4"	DIN 3852-2-X	PSQ2.1306.003	
	13	2	10	2	2	NPTF 1/4"	ANSI B1.20.3	PSQ2.1306.013	
	13	2	10	2	2	BSP 3/8"	DIN 3852-2-X	PSQ2.1310.113	
	13	2	10	2	2	NPTF 3/8"	ANSI B1.20.3	PSQ2.1310.013	
	13	2	10	2	2	BSP 1/2"	DIN 3852-2-X	PSQ2.1313.113	
	13	2	10	2	2	NPTF 1/2"	ANSI B1.20.3	PSQ2.1313.013	
	13	2	10	2	2	M16x1.5	ISO 6149-1	PSQ2.1316.103	
<b>IG 2</b>	13	2	10	2	2	9/16" - 18 UNF 2B	SAE J 1926-1	PSQ2.1315.033	
	13	2	10	2	2	3/4" - 16 UNF 2B	SAE J 1926-1	PSQ2.1319.033	
	13	2	10	2	2	M22x1.5	SAE J 2244/1	PSQ2.1322.103	
<b>AG 5</b>	13	2	10	2	2	BSP 1/2"	BS B5200	PSQ2.1313.703	

THREADS

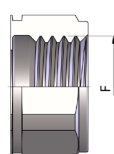

IG 1

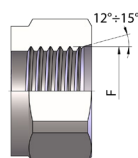

IG 2

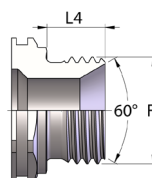

AG 5

## FIXED PLATE PSQ2

POS.	PART NUMBER	WEIGHT (g)
1	PSQ.220.100	
2	PSQ.KIT.020	
3	PSQ.KIT.017	
4	PSQ.000.016	
5	SEE SPARE PARTS ISO 10	

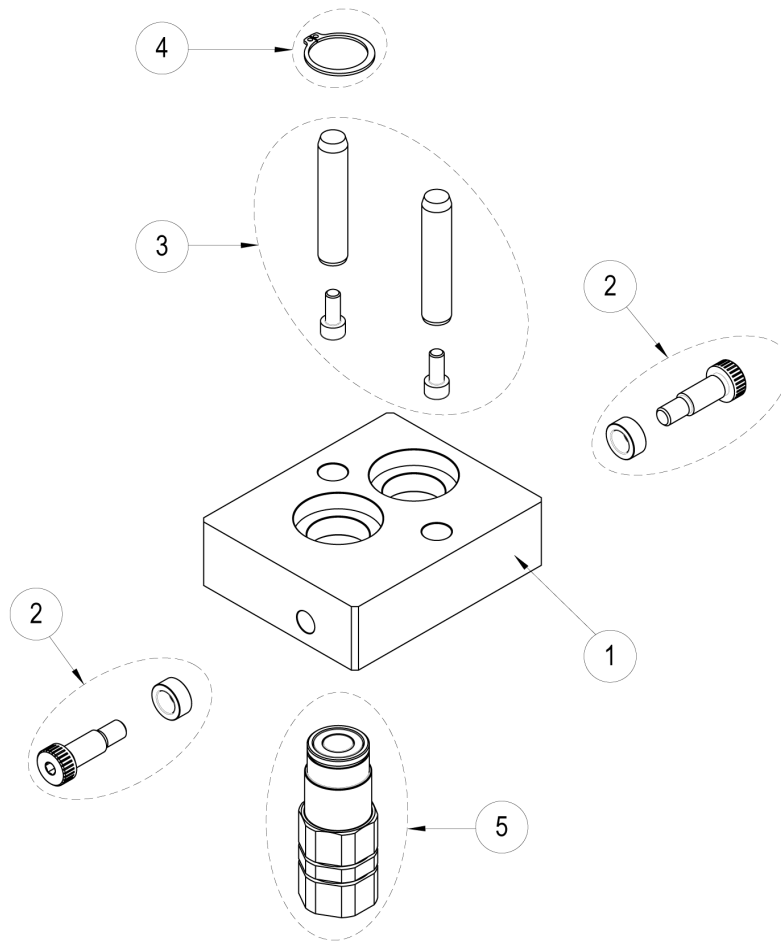

## MOBILE PLATE PSQ2

POS.	PART NUMBER	WEIGHT (g)
6	PSQ.320.300	
7	PSQ.KIT.011	
8	PSQ.KIT.050	
9	PSQ.KIT.042	
10	PSQ.000.022	
11	SEE SPARE PARTS ISO 10	

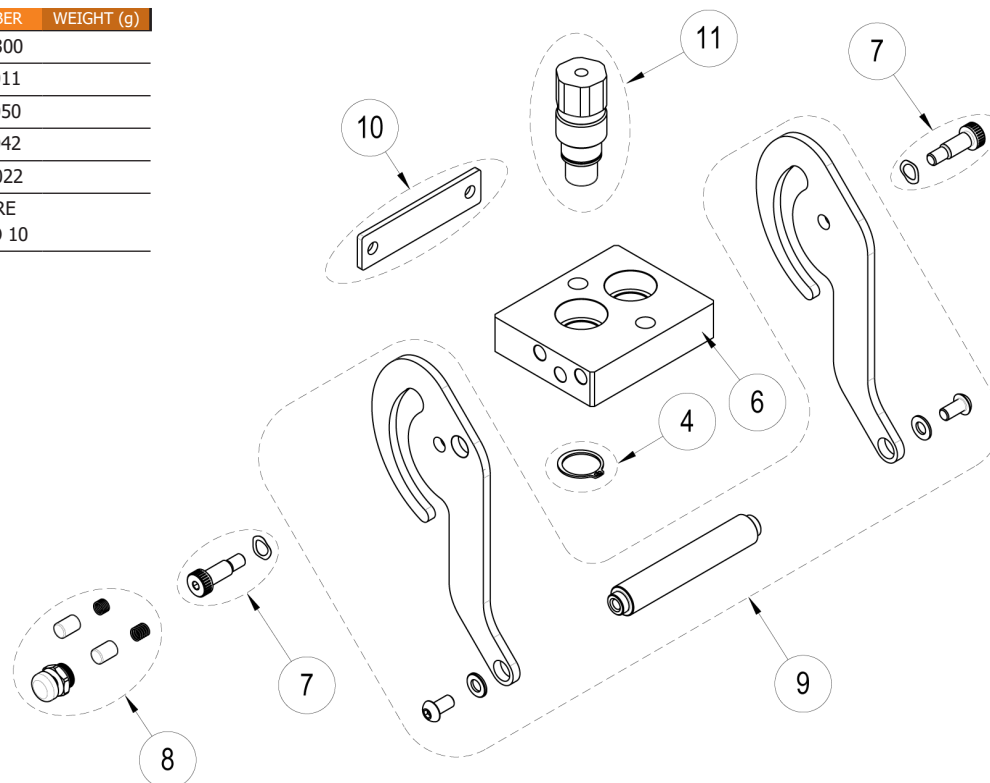

## SPARE PARTS ISO 10 COUPLINGS

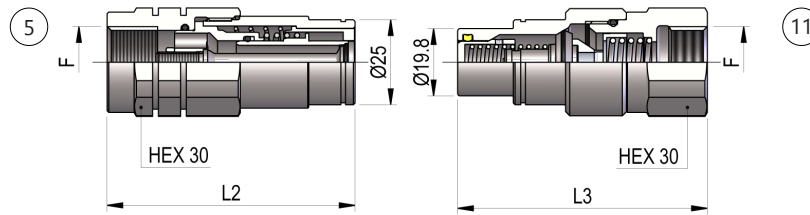

DNP	BG	ISO	L2	L3	L4	Thread F	STANDARD	SPARE PARTS CODE			
								FEMALE - MUFFE		MALE - STECKER	
13	2	10						COD. F	Weight (g)	COD. M	Weight (g)
<b>IG 1</b>			73.5	74		BSP 1/4"	DIN 3852-2-X	POT4.1306.112		POT4.1306.113	
			73.5	75		NPTF 1/4"	ANSI B1.20.3	POT4.1306.012		POT4.1306.013	
			73.5	74		BSP 3/8"	DIN 3852-2-X	POT4.1310.112		POT4.1310.113	
			73.5	77.5		NPTF 3/8"	ANSI B1.20.3	POT4.1310.012		POT4.1310.013	
			73.5	74		BSP 1/2"	DIN 3852-2-X	POT4.1313.112		POT4.1313.113	
			73.5	78		NPTF 1/2"	ANSI B1.20.3	POT4.1313.012		POT4.1313.013	
			73.5	74		M16x1.5	ISO 6149-1	POT4.1316.102		POT4.1316.103	
			73.5	74		M18x1.5	ISO 6149-1	POT4.1318.102		POT4.1318.103	
<b>IG 2</b>			72	75		9/16" - 18 UNF 2B	SAE J 1926-1	POT4.1315.032		POT4.1315.033	
			73.5	75		3/4" - 16 UNF 2B	SAE J 1926-1	POT4.1319.032		POT4.1319.033	
			74.5	75		M22x1.5	SAE J 2244/1	POT4.1322.102		POT4.1322.103	
<b>AG 5</b>			75	75	13	BSP 1/2"	BS B5200	POT4.1313.702		POT4.1313.703	

## SPARE PARTS SEALS

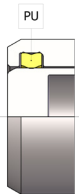

NOMINAL SIZE			MALE GASKET
DNP	BG	ISO	PU (POLYURETHANE)
13	2	10	PLK.013.210

### THREADS

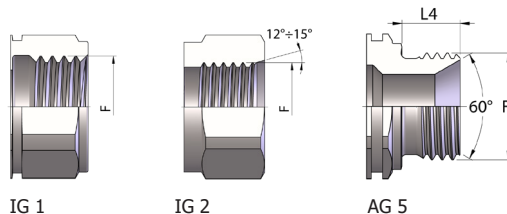

**DOCKING STATION**

**PLATE CAP**

POS.	PART NUMBER	WEIGHT (g)
1	PPSQ.220	

POS.	PART NUMBER	WEIGHT (g)
1	SPSQ.220	

